

Motic®

MORE THAN MICROSCOPY



AE2000MET | INVERTED METALLURGICAL MICROSCOPE



AE2000MET | INVERTED METALLURGICAL MICROSCOPE

AE2000MET BF/DF series inverted industrial microscope, constructed by MOTIC a world leader in Microscope manufacturing is dedicated to providing a solution for every observation and inspections. Also on such items as irregular, large size, rigid samples. This includes metal parts, materials, mineral, die casting and precision molds etc., which is not convenient to be observed or inspected under upright Microscope for failure analysis, material research or quality control purpose. And it is also **cost saving due to the requirement-less to sample making**. Fit field includes automotive, aerospace, machinery, tooling fabrication and iron&steel industry etc. industrial realm.

The overall optical performance of the AE2000MET series is superb and unique for reproducing a real micro-world of material structure for you, via equipping with a new generation of BF and DF Long working distance Metallurgical plan objective be made of high-quality glass and upgrade anti-reflex coating tech, combining a variety of observation methods of BrightField, Darkfield, simple Polarizing etc., AE2000MET is suitable for whatever failure analysis or material research or quality control in all industry.







Objectives

The AE2000MET offers a completely upgraded class of Bright Field and Dark Field metallurgical LWD lenses upon CCIS Infinity Optics concept of Motic, which have been achieved new breakthrough on the reproduction accuracy, contrast and transmission via optimizing the multi-layer coating tech and improving lens quality, can presents a brighter true image for you.

Description	N.A.	W.D.(mm)
LM Plan BD 5X	0.13	17.3
LM Plan BD 10X	0.25	16.3
LM Plan BD 20X	0.4	7.3
LM Plan BD 50X	0.55	7.2
LM Plan BD 100X	0.80	1.7
LM Plan 5X *	0.13	20.3
LM Plan 10X *	0.25	17.5
LM Plan 20X *	0.4	8.1
LM Plan 50X *	0.55	8.4

* Aspheric 100X LM Objectives (Long working distance Metallurgical objective) for bright field observation only.



Eyepiece tubes

Upon ergonomic engineering concept, each eyepiece tube allows for 360° swiveling movement as well as flexible adjustment of the interpupillary distance between 48mm and 75mm as demands. The “Butterfly mode” increases the viewing height by 40mm.

The reasonable beam split tech of 20:80 in the trinocular tube allows for the adaptation of any modern analog/digital photography documentation device. To meet the diversified demands of the applications, Motic offers a complete range of Moticam cameras in both affordable CMOS and scientific grade CCD options.

Designed with a comfortable viewing angle of 45°, all AE2000MET eyepiece tubes offer a generous 20mm Field of View (FOV 20).





Eyepieces

Motic's Infinity Corrected CCIS Optics system offers a flatness field of view 20mm. The high eye point principle of the AE2000MET's eyepieces ensures a true color and sharp images for you, so as to minimize eye fatigue and strain. The diopter adjustment of each eyepiece is an integral part to help spectacle wearers as well as optimizing reticule usage.

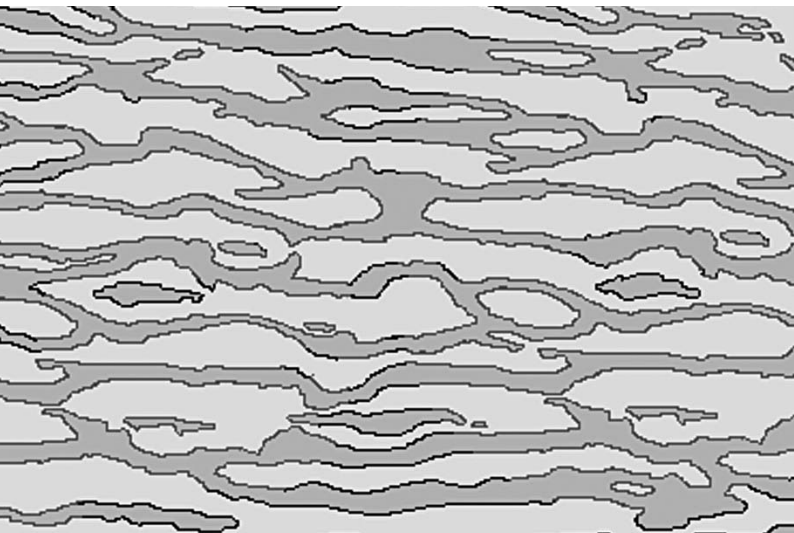

Nosepiece

The AE2000MET's ball bearing nosepiece with a special design inside can guarantee the proper parcentration and repeatability on each objective and comfortable switch consistently. A side faced orientation of the quintuple nosepiece, can totally carries on 5 different type objectives, so as to accomplish the complicated and diversified tasks and purposes efficiently in one microscope.



Stage

Whatever your sample is small or large, or irregular, or stiff sample, for the 3-plate x/y stage it is almost unlimited, and equipped with scale for movement reference.

The standard mechanical stage for AE2000MET comes with an area of 280 X180mm and has a 50x50mm travel range.



Illumination

Motic's AE2000MET supports Bright field observation, Dark field observation and Polarizing observation, coupling with the color filter, can achieves real misc observation in one microscope.

The lighting system has been significantly optimized. Standard configuration is equipped with high-intensity 12V/50W Halogen illumination, which can provides the adjustable lighting intensity as observation needs.

As a bright feature, AE2000MET employs a "sleep mode" mechanism in system via embedded an intelligent IR-sensor system. This feature can detects whether microscope is in use or idle, such as, it can automatically turns off the instrument when it is not in use for over 15 minutes, and it will re-power on the instrument automatically as well, while operator returns for work.





Bright Field (or BF) and Dark Field (or DF) observation

Against all-in-one concept, AE2000MET integrates Bright field observation and Dark field observation in one optics system and one objectives series, and provides the efficient switch between Dark field observation and bright field observation, no dismantling/installing objectives operation needs, so as to make all details of object/material structure invisible as possible in failure analysis or quality control efficiently.

Normally using Dark Field observation, the illumination of instrument is set up at high lighting intensity to guarantee the crisp contrast or accuracy, then while switch Dark Field observation to Bright Field observation, the potential light shock to eye may happened. **To eliminate the potential light shock, one intelligent feature, the Eye Protection mechanism, has been implanted in AE2000MET following the real ergonomic engineering concept**, which AE2000MET can adjust the illumination down to comfortable intensity automatically, to avoid the potential lighting shock to eyes.



Simple polarization observation

AE2000MET provides simple polarization observation mechanism to extend the complicate application of the research or analysis demands.

It just takes a single action to engage the polarizer and analyzer in the light path, and the polarizer can be rotate 360° degrees, allowing users to set a polarization at right direction to fit the observation demand.

The simple polarization set (polarizer & analyzer) enables a useful “POL contrast” and helps to improve image contrast.

Documentation

Today the documentation of the accurate digital/analog image captured from observation is becoming an extremely important competitive feature in analysis or quality control in natural sciences and industrial realm.

The new A2000MET series is compatible to connect the misc digital/analog device dedicated to performing the documentation of the accurate digital/analog image captured from observation, and Motic offers a full range of documentation imaging device, Moticam cameras series as well.



Standard Photomicrography

The traditional use of a single lens reflex camera (digital or analog) requires the trinocular version of the AE2000MET. The adaptation of the camera consists of a mechanical adapter combined with a photo eyepiece (2.5X or 4X).

The necessary T2 adapter specific to the camera model is supplied by the camera manufacturer. This setup delivers high resolution images of small fields.

Digital Documentation

A more convenient setup is provided through Motic's philosophy of easy image digitalization. The combination of the AE2000MET with a member of the Moticam series of digital cameras delivers excellent live images that can be stored for future reference. All Motic cameras come equipped with software to transform the AE2000MET into a full analysis and documentation station.

Motic offer a complete range of digital cameras, starting with a basic resolution of 1.3MP (CMOS) up to the research grade Moticam Pro Line (CCD) with a maximum of 10MP, including Monochrome and Cooled versions. These Moticam cameras deliver sharp live images with easy post-capture handling.

For further details on our range of cameras, as well as the different CCD adapters, please contact your nearest Motic office or your local authorized Motic reseller.

CCD Adapter

Newly designed CCD adapters, following the ISO standard of 38mm diameter, have improved optical characteristics to enhance image reproduction quality.

The appropriate adapter has to be chosen in relation to the chip size of the digital camera used. The following "magnifications" are available: 1X, 0.65X and 0.5X.



AE2000MET Standard Specifications

Optical System	Color Corrected Infinity Optical System [CCIS®]
Magnification	LM Plan BD: 50X-1000X
	LM Plan: 50X-1000X
Eyepieces	N-WF 10X/20mm, with diopter adjustment
Observation Tube	Widefield trinocular 45° - light distribution 20/80
Interpupillary Distance	48 ~ 75mm
Nosepiece	Left side orientated, quintuple.
Objectives	LM Plan BD: 5X, 10X, 20X, 50X
	LM Plan: 5X, 10X, 20X, 50X, 100X
Focus	Coaxial movement Coarse focus with torque adjustment Fine focus with 2µm minimum increment
Mechanical Stage	280X180mm surface; 50X50mm movement
Illumination	12V/50W halogen Koehler illumination

AE2000MET Schematic Diagrams

Unit:mm

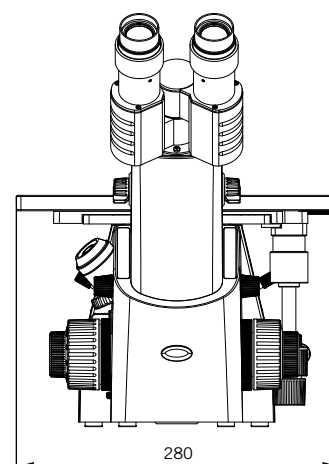
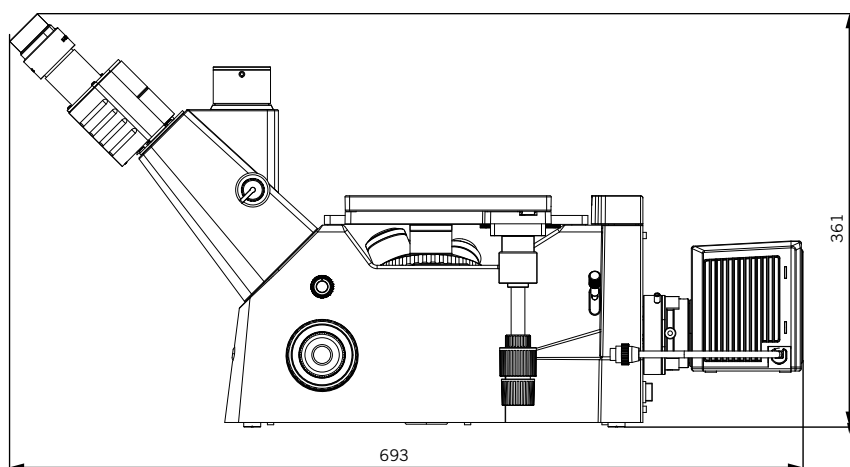

AE2000MET System Diagram

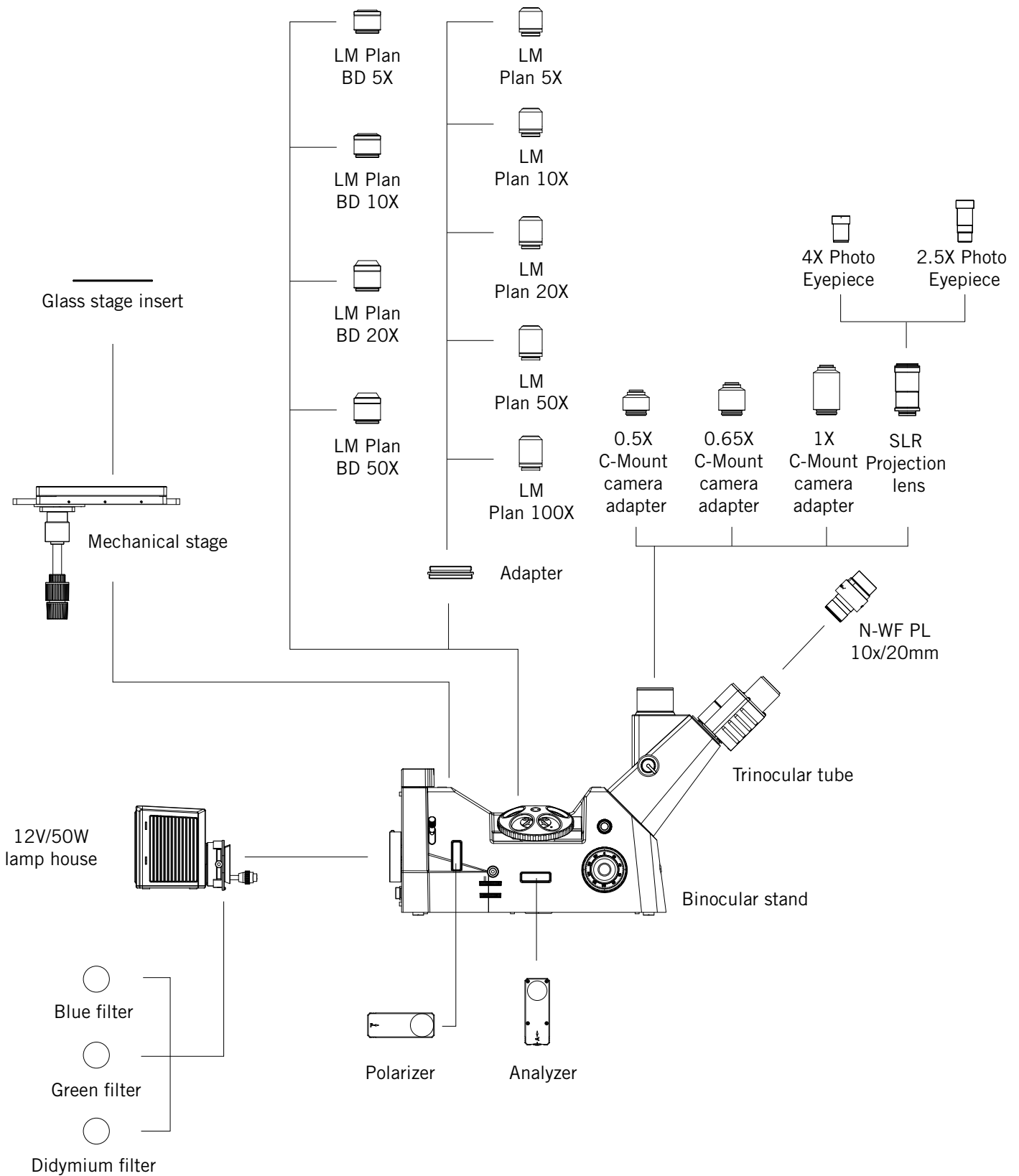



Canada | China | Germany | Spain | USA

Motic®

www.motic.com

Motic Instruments Inc. (CANADA)

130 - 4611 Viking Way. Richmond, BC V6V 2K9 Canada
Tel: 1-877-977 4717 Fax: 1-604-303 9043

Motic Deutschland GmbH (GERMANY)

Christian-Kremp-Strasse 11, D-35578 Wetzlar, Germany
Tel: 49-6441-210 010 Fax: 49-6441-210 0122

Motic Incorporation Ltd. (HONG KONG)

Rm 2907-8, Windsor House, 311 Gloucester Road,
Causeway Bay, Hong Kong
Tel: 852-2837 0888 Fax: 852-2882 2792

Motic Spain, S.L. (SPAIN)

Polígono Industrial Les Corts, Camí del Mig, 112
08349 Cabrera de Mar, Barcelona, Spain
Tel: 34-93-756 6286 Fax: 34-93-756 6287

* **CCIS®** is a trademark of Motic Incorporation Ltd.

**Motic Incorporation Limited Copyright © 2002-2013.
All Rights Reserved.**

Design Change :

The manufacturer reserves the right to make changes in instrument design in accordance with scientific and mechanical progress, without notice and without obligation.



Updated: 201309

Code: 138xxxxxxxx